

## KDT 3.60

### Rotary vane compressors

- oil-free and air-cooled
- incl. integrated suction filter and pressure regulating valve

### Drehschieber-Verdichter

- trockenlaufend und luftgekühlt
- inkl. integriertem Ansaugfilter und Druckregulierventil

### Compresseur à palettes

- fonctionnant à sec et refroidies par air
- incl. filtre d'aspiration intégré et soupape de reglage pression

### Compressori a palette

- funzionanti a secco e raffreddate ad aria
- incl. filtro di aspirazione integrato e valvola regolazione pressione

### Compresores de paletas

- sin aceite y refrigerado por aire
- incl. filtro de aspiración integrado y válvula reguladora de presión



fig.: KDT 3.80

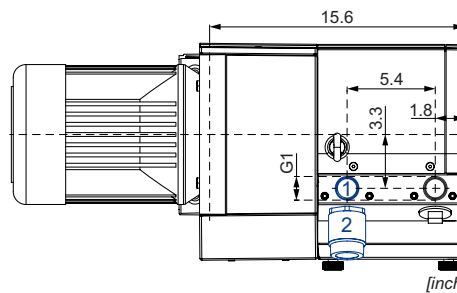
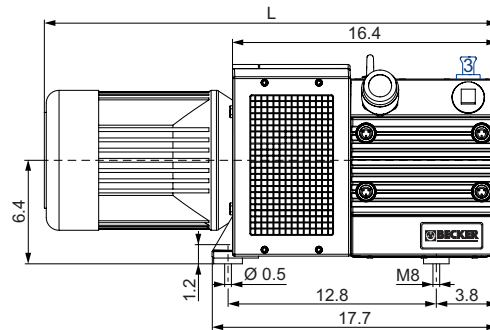
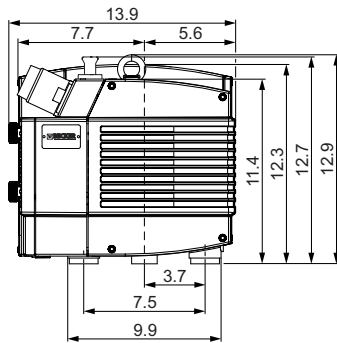

- 1 Pressure connection  
Druckanschluss  
Raccord pression  
Raccordo pressione  
Conexión de presión
- 2 Pressure regulating valve  
Druckregulierventil  
Soupape de reglage pression  
Valvola regolazione pressione  
Válvula reguladora de presión
- 3 Air nozzle  
Ansaugdüse  
Buse d'aspiration  
Ugello di aspirazione  
Boquilla de aire

CFM		PSIG		hp 3~			lbs	db(A) <sup>1)</sup>	
50 Hz	60 Hz	50 Hz	60 Hz	50 Hz	60 Hz	(M)		50 Hz	60 Hz
32	37	7.25	7.25	3.0	3.5	1-4	104 + (M)	71	73
		14.5	14.5	3.0	3.5	1-4	104 + (M)	72	74
		21.75	21.75	4.0	4.8	5-8	104 + (M)	72	74

(M)	50 Hz					60 Hz					lbs	№	L inch	
	hp	V	rpm	A	hp	V	rpm	A						
3.2/4.0hp	3~	3.0	Δ230/Y400	IE3	1440	8.2/4.8	3.5	Δ265/Y460 Δ230/Y400	IE3 -	1735 1705	8.2/4.8 9.0/5.2	63.9	42289422300003RE	27.7
							3.5	YY230/Y460 208	IE3/UL/CSA -	1763 1754	9.3/4.64 9.65			
	3~	3.0	Δ200/Y350	-	1469	10.4/6.0	3.5	Δ220/Y380-400 Δ200/Y350	IE3/UL/CSA -	1762 1755	10.0/5.8-5.8 10.2/5.9	81.6	42289453300114RE	29.4
							3.5	Δ 400	IE3/UL/CSA	1760	5.25/3.03			
4.0/4.8hp	3~	4.0	Δ230/Y400	IE3	1444	12.1/7.0	4.8	Δ265/Y460 Δ230/Y400	IE3 -	1736 1705	12.0/6.92 12.7/7.35	63.9	42489422300003RE	29.1
							4.8	YY230/Y460 208	IE3/UL/CSA -	1750 1737	12.7/6.34 13.5			
	3~	4.0	Δ200/Y350	-	1463	14.2/8.2	4.8	Δ220/Y380-400 Δ200/Y350	IE3/UL/CSA -	1755 1747	13.5/7.83-7.45 13.8/8.0	81.6	42489453300114RE	29.4
							4.8	Δ 400	IE3/UL/CSA	1758	7.6/4.4			
8	3~	-	-	-	-	-	4.8	Δ 400	IE3/UL/CSA	1758	7.6/4.4	81.6	42589454300114RE	29.4

1) DIN EN ISO 3744 (KpA = 3 dB(A))  
interval of 39.4inch, at medium load,  
both connection sides piped

DIN EN ISO 3744 (KpA = 3 dB(A))  
Abstand von 39.4inch, bei mittlerer  
Belastung, beide Seiten abgeleitet

DIN EN ISO 3744 (KpA = 3 dB(A))  
intervalle de 39.4inch, à régime moyen,  
avec dérivation des deux côtés

DIN EN ISO 3744 (KpA = 3 dB(A))  
intervallo di 39.4inch, a medio regime,  
entrambi i lati derivati

DIN EN ISO 3744 (KpA = 3 dB(A))  
intervalo de 39.4inch, en media carga,  
derivados de ambos lados

• Dimensions in inch

Maßangaben in inch

Mesures en inch

Misure in inch

Dimensiones en inch



WWW.BECKER-INTERNATIONAL.COM

Right of modification reserved  
Anderungen vorbehalten  
Sous réserve des modifications  
Sotto riserva di modificazioni  
Derecho a modificaciones reservado

29.11.2017

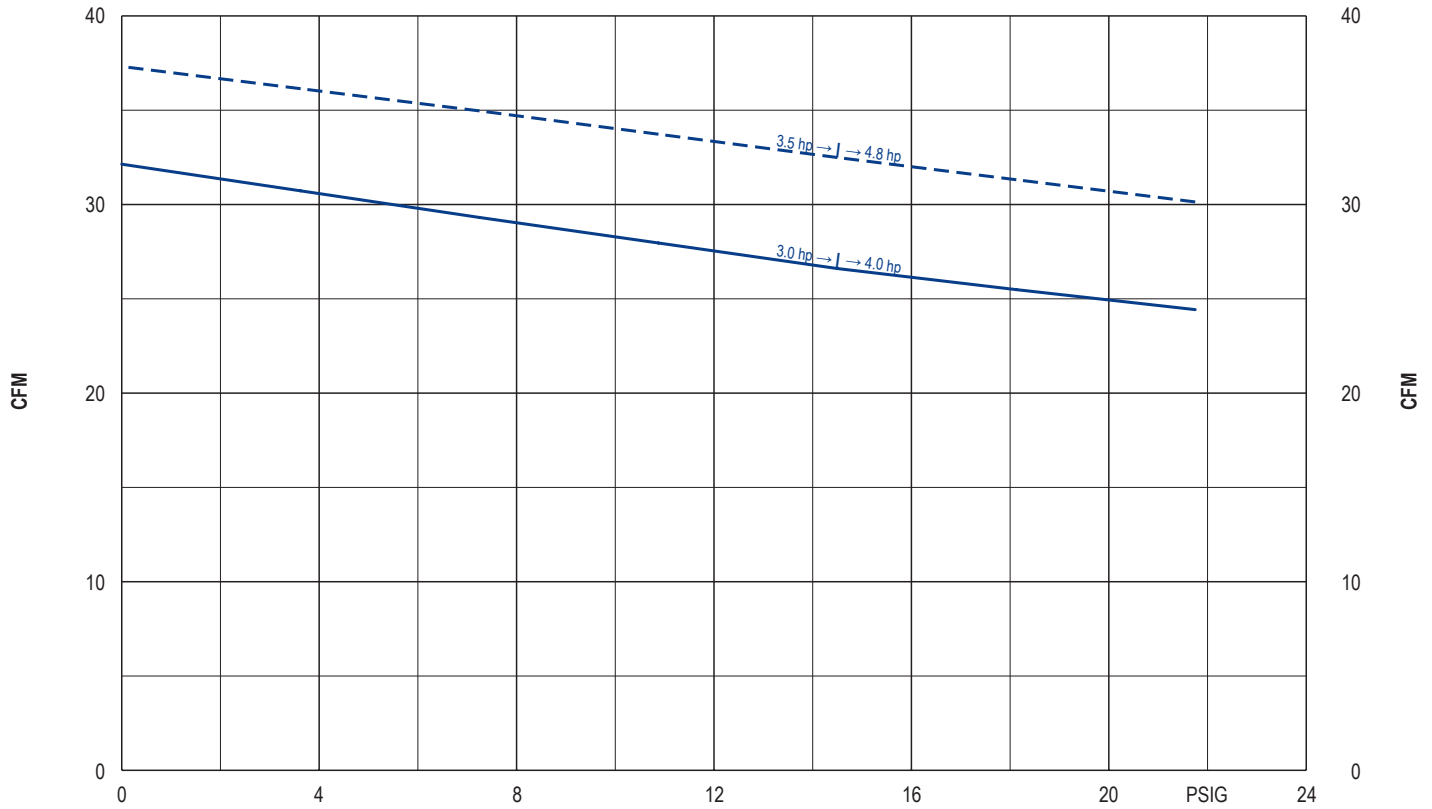

Exhaust air temperature • Ablufttemperatur • Température d'air à l'échappement  
Temperatura dell'aria scarica • Temperatura del aire de escape

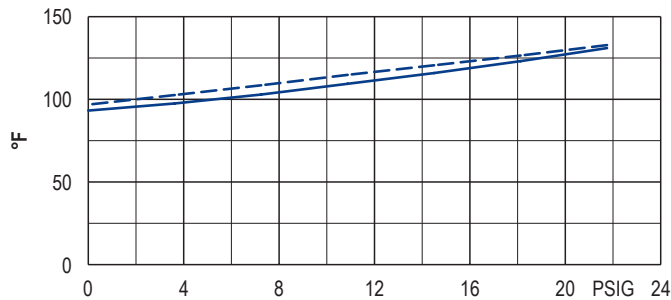

Motor shaft power • Wellenleistung • Puissance du moteur axe  
Potenza del motore albero • Capacidad de eje del motor

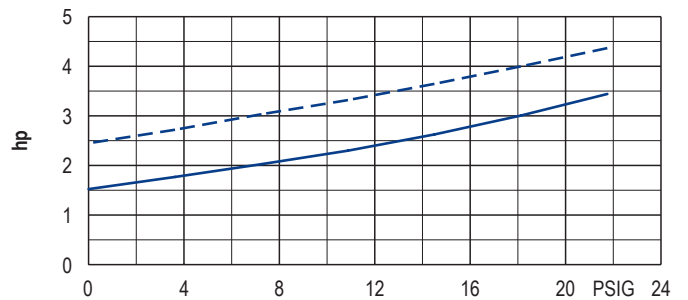

— 50 Hz  
- - - 60 Hz

▪ Reference data (atmosphere) ▪ Tolerance  
Bezugsdaten (Atmosphäre) Toleranz  
Référéce (atmosphère) Tolérance  
Riferimento (atmosfera) Tolleranza  
Referencia (atmosférica) Tolerancia  
0 PSIG, 68°F ±5%

**Variants/Accessories**

- with increased corrosion protection
- with external suction filter
- in sound proof box SH 13

**Varianten/Zubehör**

- mit erhöhtem Korrosionsschutz
- mit externem Ansaugfilter
- in Schallhaube SH 13

**Variantes/Accessoires**

- avec protection accrue contre la corrosion
- avec filtre d'aspiration externe
- dans caisse d'insonorisation SH 13

**Varianti/Accessori**

- con una maggiore protezione anti-corrosione
- con filtro di aspirazione esterno
- in casse insonorizzanti SH 13

**Variantes/Accesorios**

- con el aumento de protección contra la corrosión
- con filtro de aspiración externo
- en caja a prueba de sonido SH 13



KDX 3.60 for x-tra operating hours.

KDX 3.60 für x-tra Betriebsstunden.

KDX 3.60 pour le heures de travail x-tra.

KDX 3.60 per x-tra ore operative.

KDX 3.60 para las horas de funcionamiento x-tra.

Performance data / dimensions can differ  
Combinations on request

Leistungsdaten / Abmessungen können abweichen  
Kombinationen auf Anfrage

Données de performance / mesures peuvent différer  
Combinaisons sur demande

Dati di performance / misure possono differire  
Combinazioni su richiesta

Datos de rendimiento / dimensiones pueden diferir  
Combinaciones a petición

