



CMT 330TC

CMT 330TC THREE-KNIFE TRIMMER

PRODUCT OVERVIEW



CMT 330TC THREE-KNIFE TRIMMER

The new generation CMT 330TC Three-Knife Trimmer introduces sophisticated automation to the finishing trim operation of perfect bound books. The book trimming process no longer needs to be a labor and cost intensive task. The Challenge CMT 330TC provides professional high-quality trimming for the wide range of book sizes in today's publishing marketplace.

WIDE RANGE OF BOOK SIZES

The new Challenge CMT 330TC has expanded capability to finish cut **LANDSCAPE FORMATTED BOOKS** up to 12.1" (307mm) tall and 12.9" (328mm) wide. Designed and built in Michigan-USA, the CMT 330TC utilizes powerful hydraulic cutting and clamping pressure to effortlessly cut up to a 2" (5cm) thick book.

EFFICIENT & FULLY AUTOMATED

The CMT 330TC utilizes servo and stepper motors to accurately position books for cutting. Full digital control of the set-up allows book size changes in less than 6 seconds. There is no need to perform manual adjustments or exchange book clamps. The CMT 330TC features simultaneous in-line and near-line feeding capability. This allows the trimmer to automatically switch between feeding books directly from an in-line perfect binder or from a manually loaded near-line book pile feeder. If one system is waiting for the next book, the other system can feed the trimmer to provide maximum production throughput. Additional features include a multiple book mode which allows two books to be trimmed simultaneously to further increase production capacity. And, the new precision knife depth control provides consistent knife stroke depth reducing cut stick wear and knife adjustments.

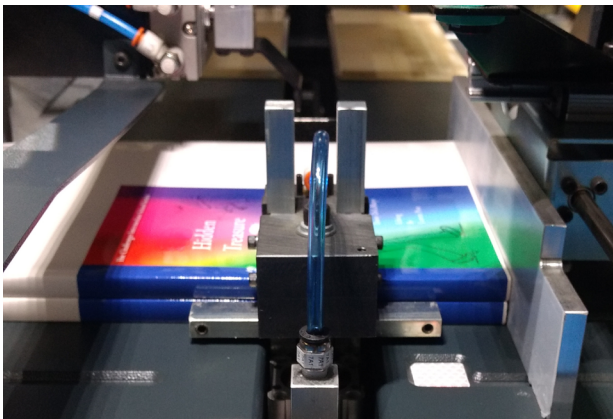

Multiple book mode increases production capacity

WORLD CLASS TECHNOLOGY

The CMT 330TC Trimmer incorporates the most advanced book trimming technology available. The new 10.5" color touch screen display, easy to use operator interface and smart diagnostic assistance makes the CMT 330TC the leader for operational simplicity. Automatic size detection of the pre-trimmed book makes job programming easy, requiring the entry of only three dimensions. Alternatively, the integrated bar code reader can scan the trim dimensions from a pre-printed barcode on the cover to adjust the knife settings automatically. Simply stated, the CMT 330TC is a fully automated book-of-one trimming solution.

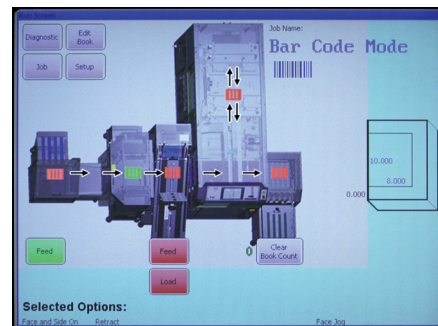

Live graphical display of book position during operation

MODULAR EXPANSION

The CMT 330TC is the only trimmer in its class that is adaptable to a wide range of production methods. The base CMT 330TC can be hand fed for a low cost, off-line solution. Adding a high capacity book pile feeder and vertical stacker enables intervals of unmanned and uninterrupted operation. When configured with an in-line feeder and cooling elevator, the CMT 330TC can be integrated with any manufacturer's perfect binder to become a complete book making system. The CMT 330TC is uniquely able to adapt as your business grows.



IN-LINE CONFIGURATION WITH ADDITIONAL BOOK PILE FEEDER

SUMMARY OF FEATURES

- Capability to trim landscape formatted books up to 12.1"/307mm x 12.9"/328mm
- Full high-speed digital control for fast and accurate set-ups in under 6 seconds
- Bar code system for fully automated set-up
- Simultaneous in-line and near-line book feeding option to maximize utilization
- Automatic size detection of untrimmed book blocks
- 10.5"/267mm color touch screen display
- Precision knife depth control reducing cut stick wear and knife depth machine adjustments
- Automated precision finish cut mode for thicker books and toner chipping issues
- Live graphical display of book path
- Thickness range up to 2"/51mm
- Hydraulic powered cutting
- No tools or clamp boards required during book size changes
- Integrated computer diagnostics with graphical display of sensor locations
- Strong knife assembly and table support design to minimize deflection
- UL Listed (US and Canada) and CE

SPECIFICATIONS - BASE MACHINE

- Memory: 99 jobs
- Book size changeover time: Under 6 seconds
- Throughput: Up to 750 books per hour in multi-book mode
- Floor load rating: 60 PSI/ 414 kPa
- Waste bin capacity: 3@14-3/4 gal. per bin / 55.8 liters per bin
- Oil capacity: 5 gallons/19 liters
- Maximum blade re-sharpening: 1/4"/6.4 mm
- Air consumption: 9 CFM @ 90 PSI/ 255 LPM @ 5.8 Bar

PERFECT BOUND BOOK SIZE (SPINE X TOP)

- Starting book maximum: 13" x 13" (330 X 330 mm)
- Starting book minimum
 - Near-line single mode: 7" x 5"/ 178mm x 127mm
 - Near-line multiple mode: 7" x 8"/ 178mm x 203mm
 - In-line single mode: 7" x 8"/ 178mm x 203mm
 - In-line multiple mode: 7" x 9"/ 178mm x 229mm
- Finished book maximum: 12.1" x 12.9" (307 x 328 mm)
- Finished book minimum: 5.82" x 3.94" (148 x 100 mm)
- Maximum top trim: 6" (152 mm)
- Minimum book thickness: .100" (2.5 mm)
- Maximum book thickness: 2" (51 mm)

ELECTRICAL UL CE

- 60 Hz, AC, 3 Phase
208/230 Volts, 20 Amps (service size 30 Amps)
- 50 Hz, AC 3 Phase
380/415 Volts, 16.5 Amps (service size 20 Amps)
- 50 Hz, AC 3 Phase
200-208 Volts, 20 Amps (service size 30 Amps)

AIR SUPPLY

- Requires a dry non-lubricated air source capable of supplying a MINIMUM of 9 CFM (254 LPM) and remain at a CONSTANT 90 PSI minimum (5.8 Bar/620 kPa)

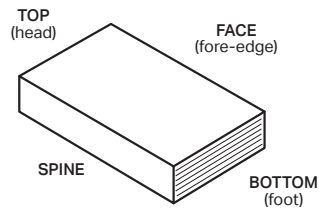

CONFIGURATION

COMPONENT	NUMBER OF SKIDS	NET WT. (approx.)	SHIPPING WT. (approx.)
Near-line - Pile Feeder & Stacker	3	3,660 lbs/ 1,660 kg	4,100 lbs/ 1,860 kg
In-line - No Pile Feeder	5	3,860 lbs/ 1,751 kg	4,557 lbs/ 2,067 kg
In-line - With Pile Feeder	6	4,290 lbs/ 1,946 kg	5,057 lbs/ 2,294 kg

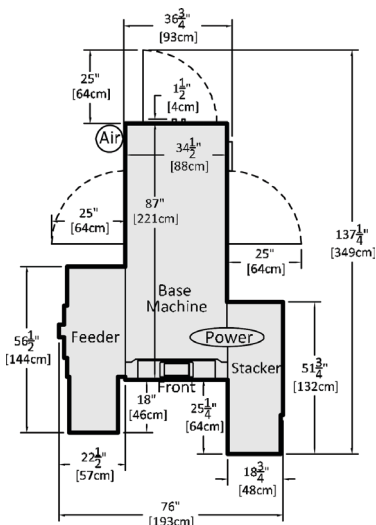

NEAR-LINE

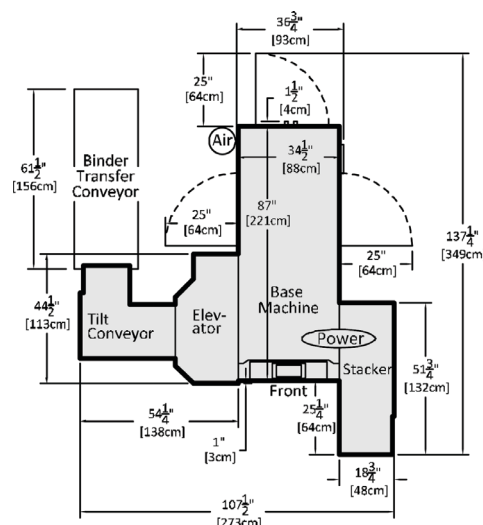

IN-LINE NO FEEDER

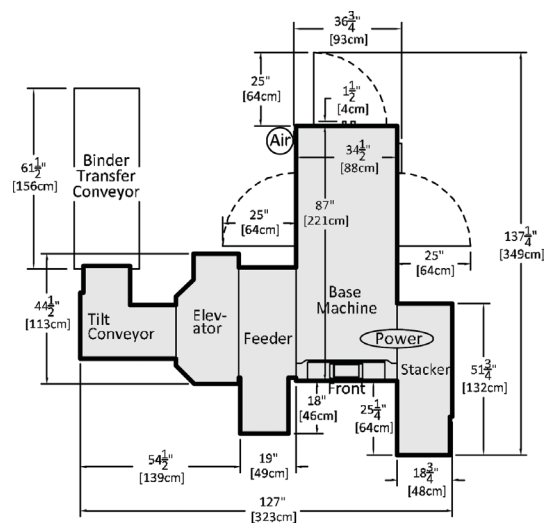

IN-LINE WITH FEEDER



THE CHALLENGE MACHINERY COMPANY
 6125 Norton Center Dr. Norton Shores, MI 49441 USA
 P. 231.799.8484 F. 231.798.1275 www.challengemachinery.com
 +1.231.799.8484

