

**Horizon**

# FoldLiner

Saddle-Stitching System

## New Hybrid Approach to Saddle Stitched Booklets from Press Sheet!

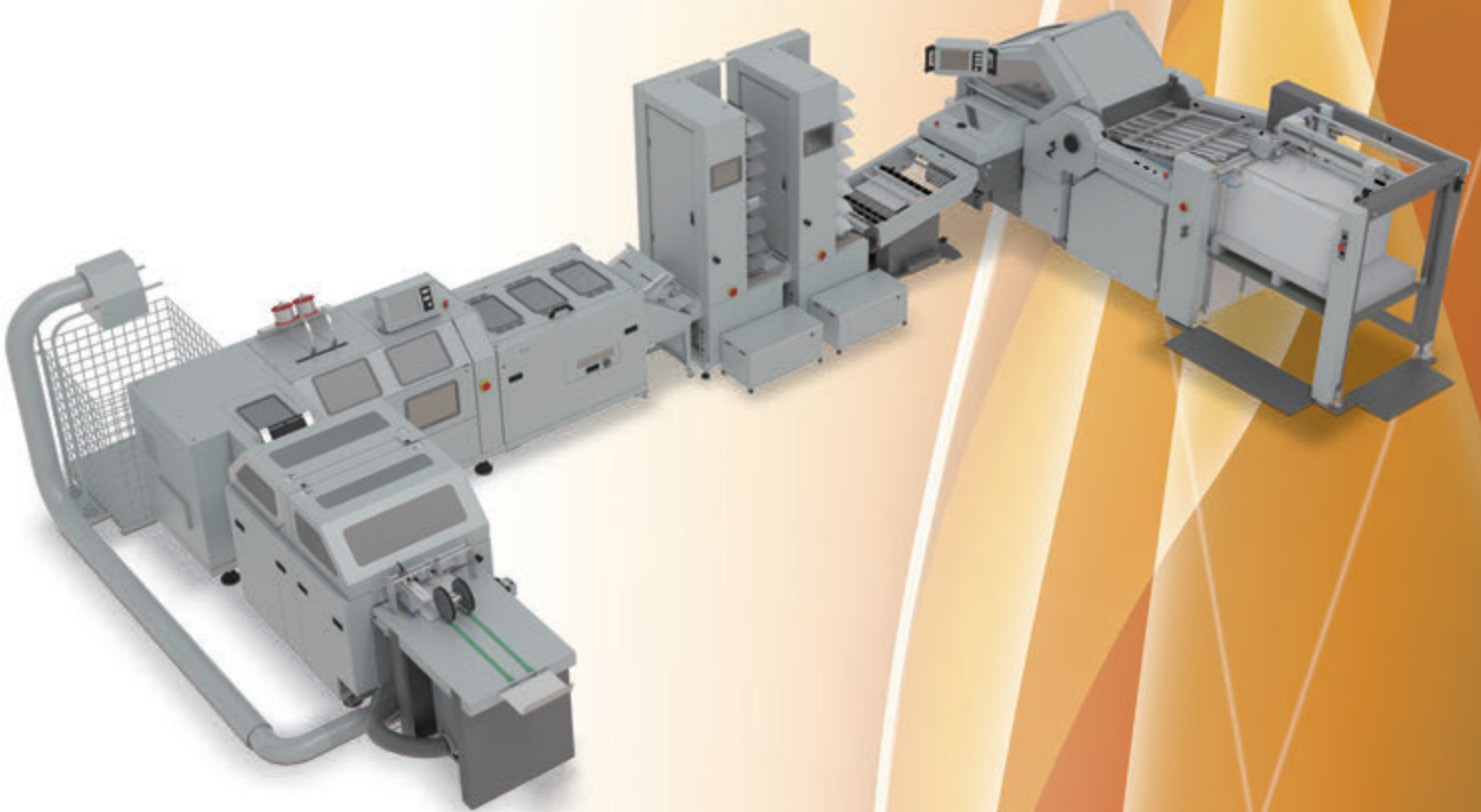

### Features

---

- 1. No touch points** - The FoldLiner combines the AFC-74 Series Folder and the StitchLiner6000 Saddle-Stitching System. No additional offline processing is required after printing for finished booklet production.
- 2. High Productivity** - Flat sheet to saddle stitched booklet can be produced up to 6,000 booklets per hour.
- 3. Variable Production** - Variable sheet count production can be achieved by use of optional mark sensor. Suitable for digitally printed B2 size sheet and full size press sheets.

Eliminate the folding process and go from digital or offset press sheet to saddle stitched booklet using a single operator.

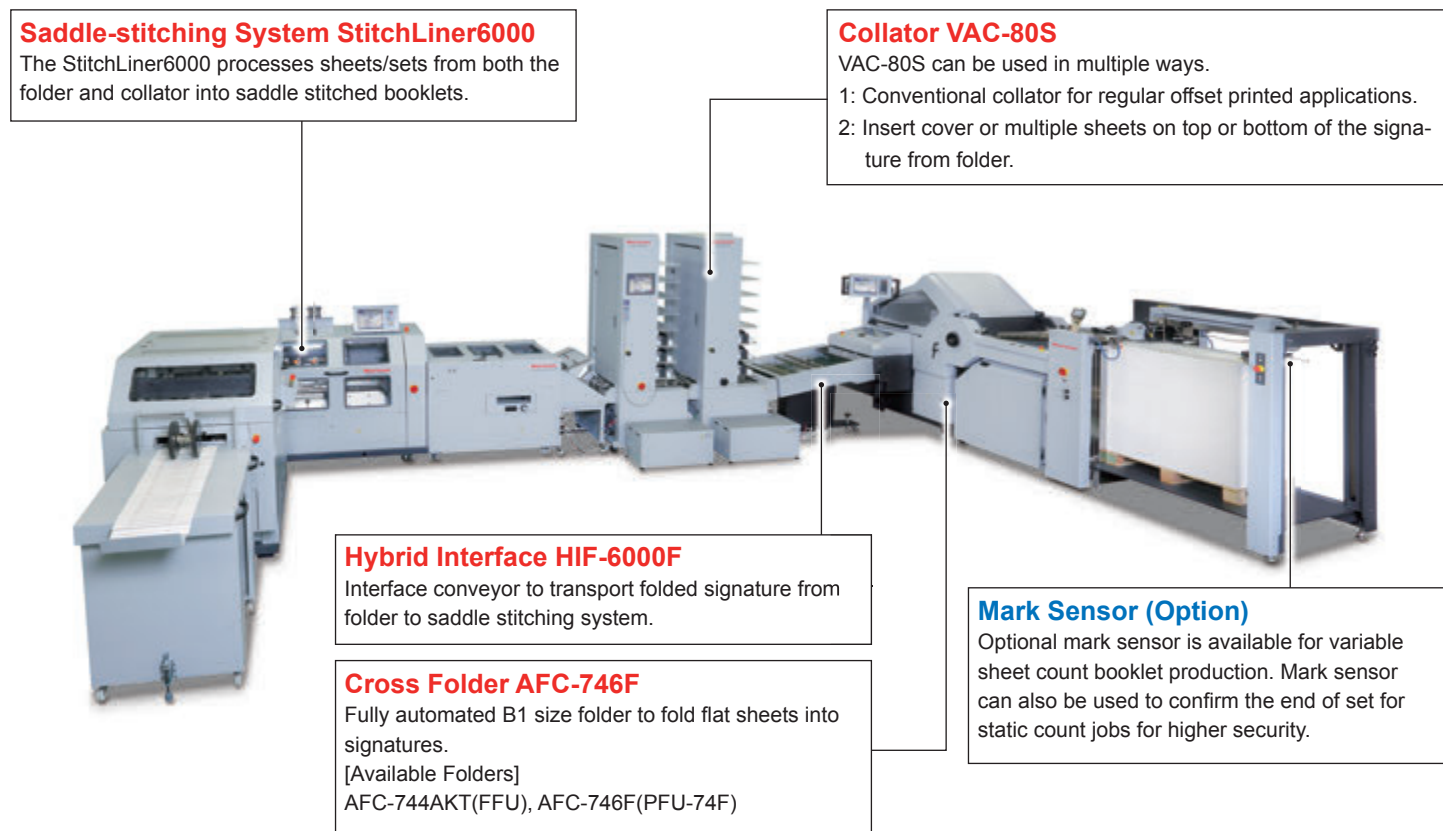

**Saddle-stitching System StitchLiner6000**  
The StitchLiner6000 processes sheets/sets from both the folder and collator into saddle stitched booklets.

**Collator VAC-80S**  
VAC-80S can be used in multiple ways.  
1: Conventional collator for regular offset printed applications.  
2: Insert cover or multiple sheets on top or bottom of the signature from folder.

**Hybrid Interface HIF-6000F**  
Interface conveyor to transport folded signature from folder to saddle stitching system.

**Mark Sensor (Option)**  
Optional mark sensor is available for variable sheet count booklet production. Mark sensor can also be used to confirm the end of set for static count jobs for higher security.

**Cross Folder AFC-746F**  
Fully automated B1 size folder to fold flat sheets into signatures.  
[Available Folders]  
AFC-744AKT(FFU), AFC-746F(PFU-74F)

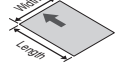
Specifications of the FoldLiner	
Model Name	AFC-746F (PFU-74F) + HIF-6000F + VAC-80S + StitchLiner6000
Sheet Size	<p>Fold, Saddle-stitch and Trim</p> <ul style="list-style-type: none"> <li>When the AFC-744A or AFC-746F (feeding by the FFU) is connected It is the same as the normal AFC-744A and AFC-746F. Max. 738 x 1,100 mm or 29.05" x 43.30" Min. 210 x 210 mm or 8.27" x 8.27"</li> <li>When the sheets are fed from the VAC-80S It is the same as the normal StitchLiner6000. Max. 356 x 508 mm or 14" x 20" Min. 140 x 199 mm or 4.73" x 7.09"</li> </ul> 
Sheet Weight Range	Normal Paper: 53 to 157 gsm Art Coated Paper: 74 to 210 gsm
Stitch Thickness	It is the same as the normal StitchLiner6000.

Finished Book Size	It is the same as the normal StitchLiner6000.
StitchLiner Production Speed	Maximum 6,000 booklets per hour (A4 of 16 Pages)
	<ul style="list-style-type: none"> <li>* When the Fold Digital mode or Mix Digital mode is selected, the StitchLiner6000 Digital is in the intermittent run mode and the production speed becomes 2,200 booklets per hour.</li> <li>* When the signatures and sheets from the collator are fed in the sub-set mode, the production speed becomes 2,200 booklets or less per hour.</li> <li>* The production speed changes depending on the configuration of the system, settings, jobs or sheets.</li> </ul>

\*1 • For the center cut, the thickness of booklet is 3 mm or 0.12" at the maximum.  
(When the center knife of 8 mm or 0.31" width is used, the thickness of booklets is 4 mm at the maximum.)  
• For the punch, the thickness of booklets is 3 mm or 0.12" at the maximum.  
• For the stitching thickness larger than 3 mm or 0.12", the wires for thick stitching (#23, #24) are necessary.  
• For loop stitching, the thickness of booklets is 6 mm at the maximum.

\*The machine design and specifications are subject to change without any notice.

Distributed by

**HORIZON INTERNATIONAL, INC.**

510 Kuze Ooyabu-cho, Minami-ku, Kyoto, 601-8206, Japan Phone : +81-(0)75-934-6700, Fax : +81-(0)75-934-6708, www.horizon.co.jp