

Horizon



SB-07

7-Clamp Perfect Binder

**Compact and High-Speed Perfect Binder
for short-run production.**

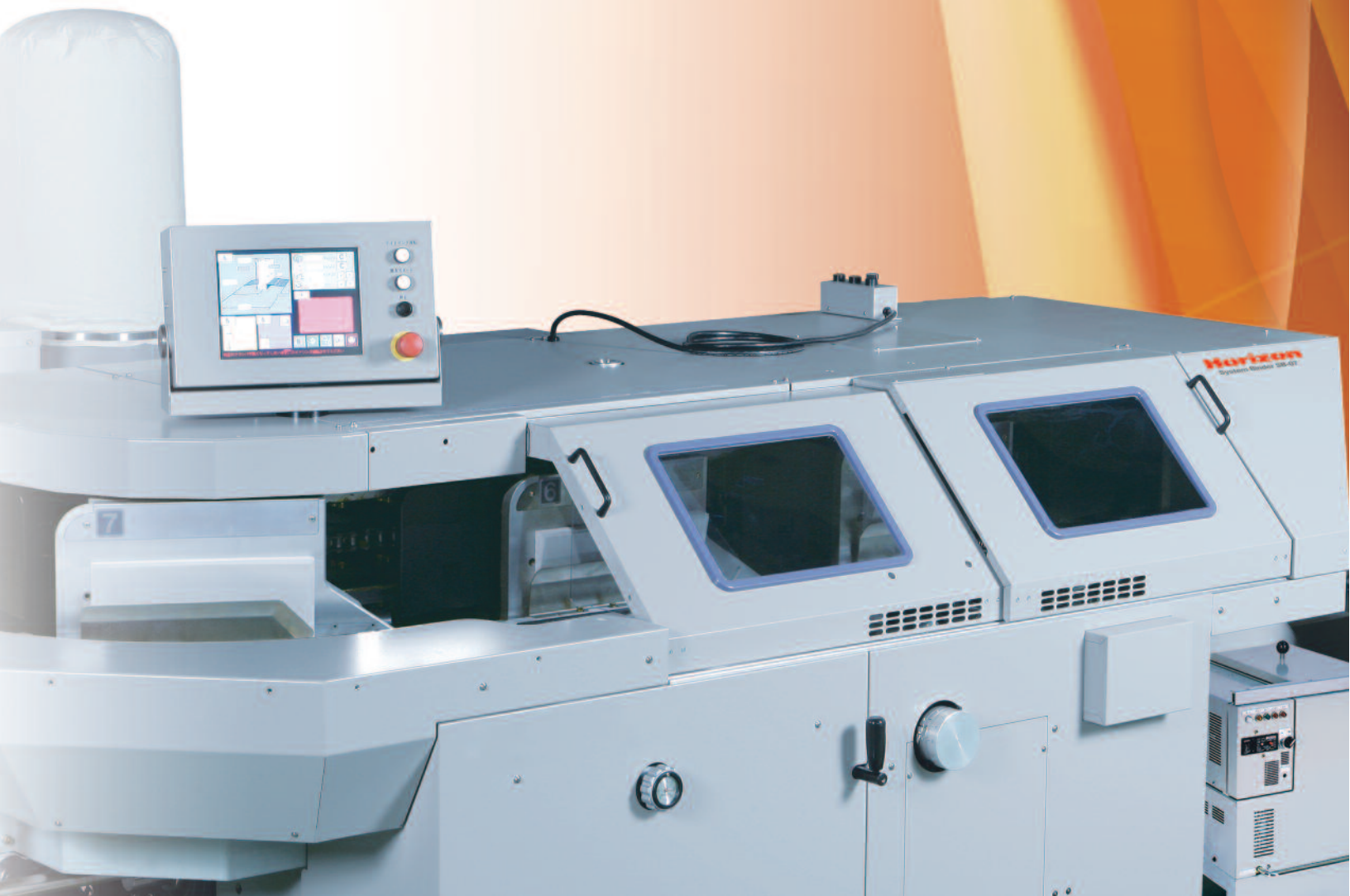

With semi-automated setup, 7-clamps, and up to 3,200 books per hour, the SB-07 fits your book production needs -- from short runs up.

Features

1. High speed production - Max. 3,200 books per hour.
2. Binding books up to 45 mm / 1.77" thick.
3. Semi-automated setup for quick changeover and easy operator fine tuning.
4. User-friendly operation through large color touchscreen.
5. Dual application rollers with side gluing to ensure stronger binding result.
6. Suction cover feeder handles a wide range of cover substrates.
7. Connectable to in-line three-knife trimmer.

Automated Setup

- Milling Guide Width
- Side Glue Width
- Guide Width at Cover Feeder
- Scoring Roller Position
- Guide Width at Cover Sheet Register Section
- Nipper Width

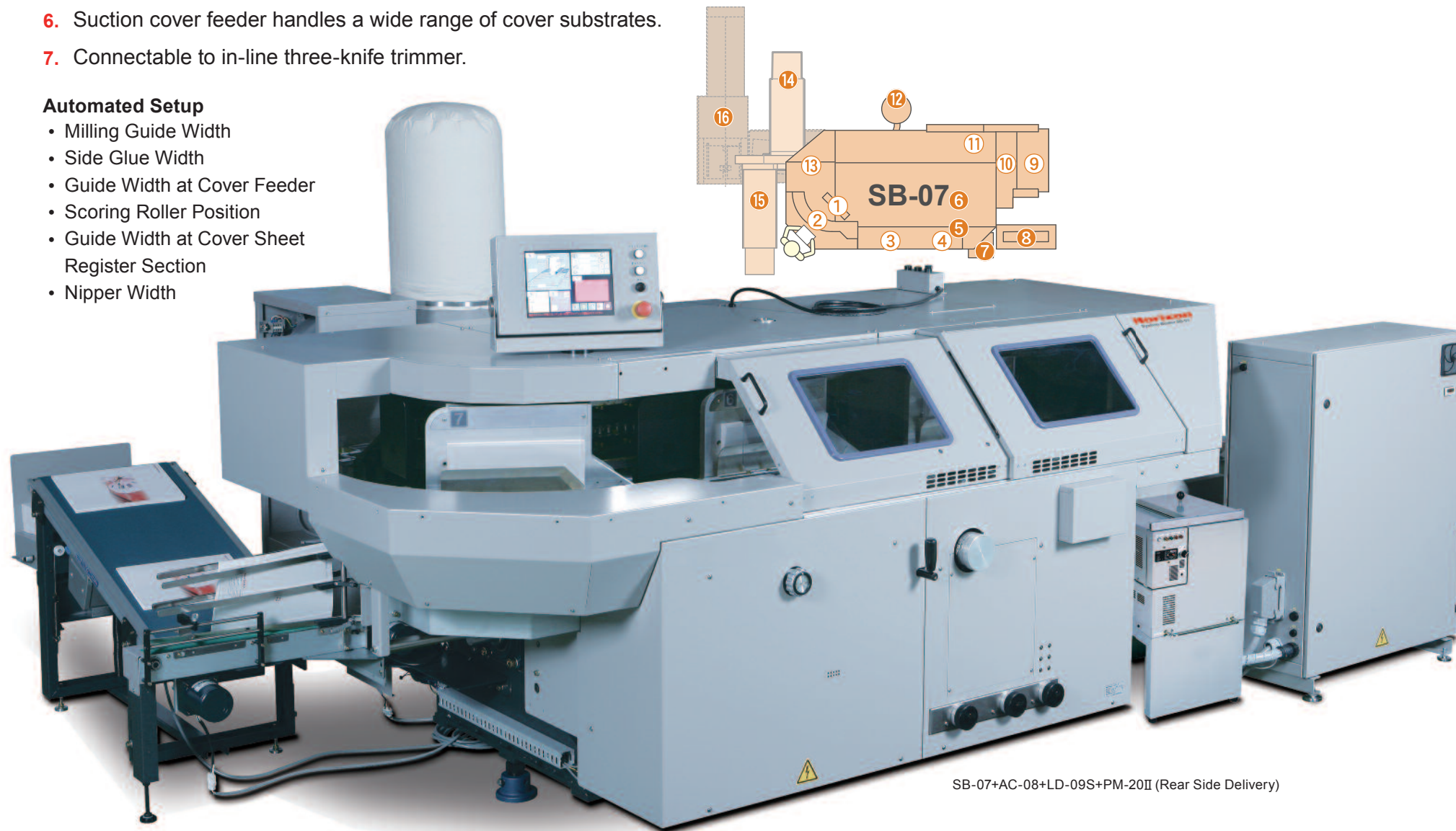

SB-07+AC-08+LD-09S+PM-20II (Rear Side Delivery)

Color Touchscreen ①



10.4 inch color touchscreen provides book size input, function setups, fine-adjustment, and trouble monitoring.

Book Block Feeding ②



Comfortable working space is provided at the book block feeding section. Built-in jogger helps align the book block.

Book Thickness Adjust ③

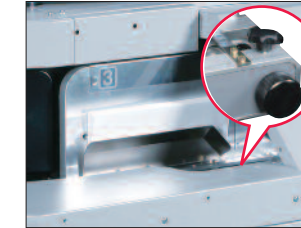

A knob at each clamp easily adjusts clamp opening, to handle book thickness ranging from 2 to 45 mm / 0.08" to 1.77".

Milling Section ③

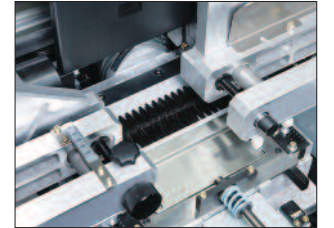

A larger diameter milling blade is provided. Milling blade rotation speed and notching pitch can be adjusted.

Glue Application ④



Dual application rollers ensure the glue penetrates deep into the book spine. Side gluing setup can be performed through LCD touchscreen.

Cover Feeder ⑨

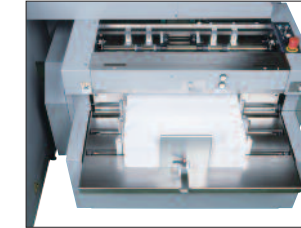

The cover sheet is fed from the top of the pile for markless feeding. Maximum cover pile height is 150 mm / 5.90".

Cover Scoring ⑩



The cover scoring position is setup automatically by inputting the book size data. Pressure on scoring wheels is adjustable.

Cover and Book Registration ⑪

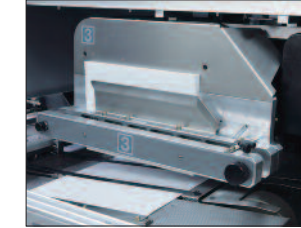

A built-in matching mechanism guarantees precise alignment of the cover to the book block from first book to last.

Delivery Section ⑬

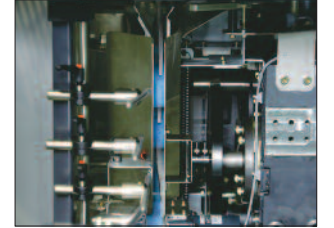

After cover registration, the bound book is delivered to the conveyor. The elevator-type delivery system keeps the book spine from damage.

Milling Blower Unit (DB-07/DB-07H) ⑫

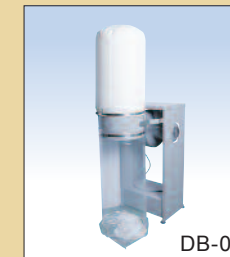

Paper chips are drawn by the powerful DB-07H vacuum system into a plastic bag for easy disposal.

Smoke Extractor (VS-09) ⑥

Extracts any smoke or fumes from the hot melt glue.

Delivery Conveyor

Selection 1



LD-09S+AC-08 (Rear Side)

Choose either front or rear side delivery for this spring-loaded catch tray.

Selection 2



LD-07+AC-08 (Operation Side)

Selection 3



LD-09L+SCH-15+CV-101

Piles predetermined number of books and delivers them to the CV-101 roller conveyor.

7-Clamp Perfect Binder SB-07

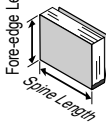
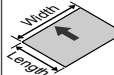
SB-07 Major Specifications							
Number of Carriage Clamps	7						
Book Block Size							
	<table border="1"> <thead> <tr> <th colspan="2">Spine Length x Fore-edge Length</th> </tr> </thead> <tbody> <tr> <td>Portrait</td> <td>Max. 400 x 320 mm / 15.75" x 12.6" (B4 wide) Min. 135 x 105 mm / 5.32" x 4.13" (A6)</td> </tr> <tr> <td>Land Scape</td> <td>Max. 400 x 320 mm / 15.75" x 12.6" (B4 wide) Min. 135 x 105 mm / 5.32" x 4.13" (A6)</td> </tr> </tbody> </table>	Spine Length x Fore-edge Length		Portrait	Max. 400 x 320 mm / 15.75" x 12.6" (B4 wide) Min. 135 x 105 mm / 5.32" x 4.13" (A6)	Land Scape	Max. 400 x 320 mm / 15.75" x 12.6" (B4 wide) Min. 135 x 105 mm / 5.32" x 4.13" (A6)
Spine Length x Fore-edge Length							
Portrait	Max. 400 x 320 mm / 15.75" x 12.6" (B4 wide) Min. 135 x 105 mm / 5.32" x 4.13" (A6)						
Land Scape	Max. 400 x 320 mm / 15.75" x 12.6" (B4 wide) Min. 135 x 105 mm / 5.32" x 4.13" (A6)						
Book Thickness	2 to 45 mm / 0.08" to 1.77"						
Cover Size	 <table border="1"> <thead> <tr> <th colspan="2">Length x Width</th> </tr> </thead> <tbody> <tr> <td>Max.</td> <td>380 x 660 mm / 14.96" x 25.98"</td> </tr> <tr> <td>Min.</td> <td>135 x 220 mm / 5.32" x 8.67"</td> </tr> </tbody> </table>	Length x Width		Max.	380 x 660 mm / 14.96" x 25.98"	Min.	135 x 220 mm / 5.32" x 8.67"
Length x Width							
Max.	380 x 660 mm / 14.96" x 25.98"						
Min.	135 x 220 mm / 5.32" x 8.67"						
Cover Weight Range	82 to 302 gsm Normal Paper 105 to 348 gsm Coated Paper						
Cover Stack Height	Max. 150 mm / 5.91"						
Production Speed	Max. 3,200 books per hour						
Voltage/Frequency	3-phase 200 V, 50 / 60 Hz 3-phase 220 V, 50 / 60 Hz (Step down to 200 V by Transformer) 3-phase 400 V, 50 / 60 Hz (Step down to 200 V by Transformer)						
Machine Dimensions	W3,431 x D1,700 x H1,150 mm / W135.1" x D67.0" x H45.3"						

SB-07 Standard Equipment		
Selection 1	Chute Delivery Conveyor	LD-09S
	Angle Conveyor	AC-08
Selection 2	Chute Delivery Conveyor	LD-07 / LD-07L
	Angle Conveyor	AC-08
Selection 3	In-line Delivery Conveyor	LD-09L
	Delivery Stacker	SCH-15
	Delivery Roller Conveyor	CV-101
	Smoke Extractor	VS-09
	Milling Blower Unit (Single)	DB-07 / DB-07H

Machine Dimensions Unit : mm (inch)

SB-07+LD-09S+AC-08 (Selection 1)

Height = 1,150 / 45.3"

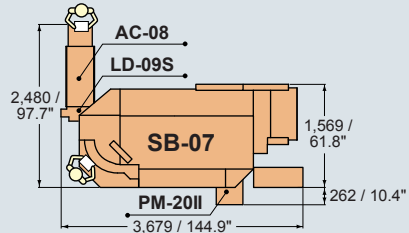

SB-07+LD-07+AC-08 (Selection 2)

Height = 1,150 / 45.3"

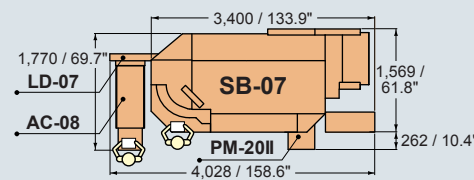

SB-07+LD-09L+SCH-15+CV-101 (Selection 3)

Height = 1,150 / 45.3"

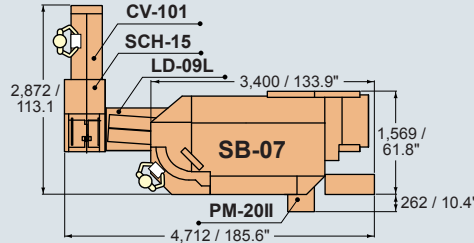

DB-07

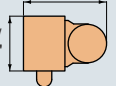

DB-07H

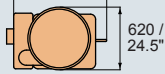

Transformer
for 220-240 V

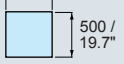

Transformer
for 400 V

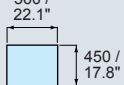

SB-07 Options

Pre-Melt Tank (PM-20II) 7



Adhesive is pre-melted and fed into the glue tank as needed.

Book Size Input Calliper (SI-15) 8

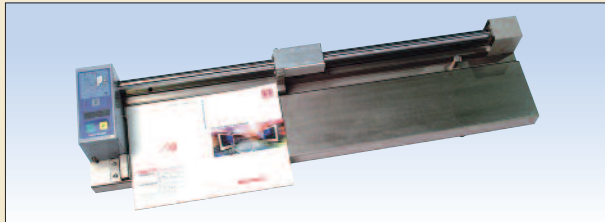

Measures the dimensions of the actual book block to be bound and sends those values to the binder.

Side Glue Level Sensor (SGD-07) 5

Informs when glue needs replenishment via audible signal and the touchscreen.

*The machine design and specifications are subject to change without any notice.