

→ SPRINT 5000 BOOKLETMAKER

jogs, staples, and folds in one operation | quick and easy set-up and adjustment | variable speed | produces booklets up to 88 pages (off-line)* | on-line saddle, corner, and side stapling capability | "fold only" capability | heavy-duty staple clinchers produce "flat-finish" staples | 2 stapling heads, 5 stapling positions | uses high-capacity, 5,000-staple cartridges | auto-stop and signal when staple cartridge is empty | powered exit conveyor | transparent safety access cover—machine will not operate with cover in open position | mounted on heavy-duty casters | interfaces with wide range of collators including the MBM FC 10 | optional face trimmer

Dimensions (D x W x H): 23 x 46 x 36 inches (20 W with conveyor stored), Shipping weight: 280 lbs.



SAFETY ACCESS COVER

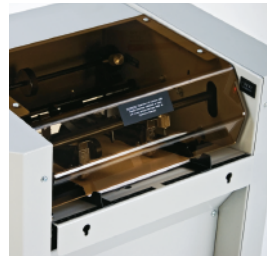

The transparent safety access cover will not allow machine to operate when open.

POWERED CONVEYOR



A powered exit conveyor stacks booklets neatly and folds away for compact storage.

OPTIONAL TRIMMER

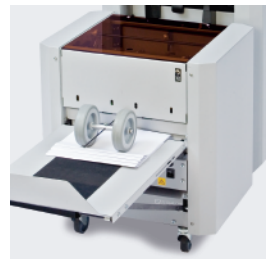

An optional face trimmer trims booklets up to 100 pages.*

→ SPRINT 5000

Speed	1,500 sets/hr*
Sheet capacity	22*
Paper size	5 1/2" x 8" to 12" x 18"
Power supply	115 V, 60 Hz

* may vary due to variations in paper and power supply

Dealer:

MBM
CORPORATION

3134 Industry Drive
North Charleston, South Carolina 29418
800-223-2508, fax: 843-552-2974
www.mbmcorp.com

IDEAL.MBM
CORPORATION

1675 Sismet Road, unit 4
Mississauga, Ontario L4W 4K8
800-387-2528, fax: 905-840-1114
www.ideal-mbm.com

SPRINT TRIMMER

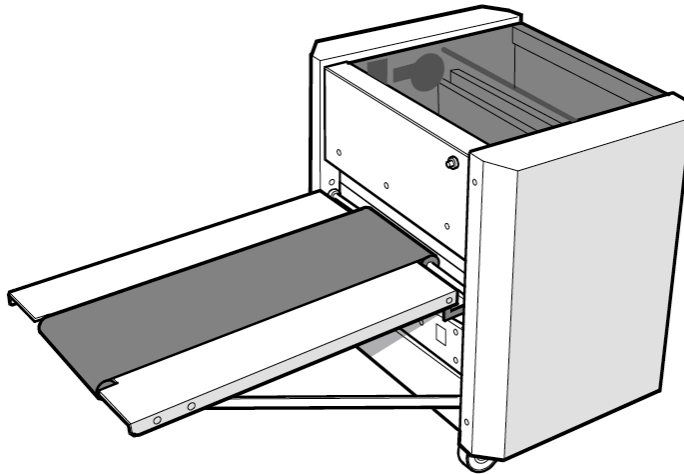

TRIMMER SPECIFICATIONS:

Max. Cutting Height: 50 sheets of 80 GSM bond

Book Sizes: 5 1/2" x 4 1/4" to 11" x 8 1/2"

Dimensions: Width: 22 1/2"
Height: 24 1/2"
Length: 19 1/4" (Conveyor stored)
Length: 40" (Conveyor in use)

Weight: 185.2 Lbs.

Power: 110v 60Hz
Consumption approx. 180 Watts
Fuse: Mains inlet - 10 amp 110 V.
24 Vdc power supply - 2.5 amp 110 V

Dealer:

MBM
CORPORATION

3134 Industry Drive
North Charleston, South Carolina 29418
800-223-2508, fax: 843-552-2974
www.mbmcorp.com

IDEAL.MBM
CORPORATION

1675 Sismet Road, unit 4
Mississauga, Ontario L4W 4K8
800-387-2528, fax: 905-840-1114
www.ideal-mbm.com